

Flymo

 Electrolux

RE 320 RE 32

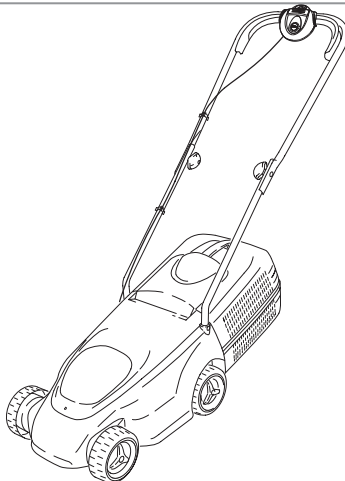

GB

IMPORTANT INFORMATION

Read before use and retain for future reference

DE

WICHTIGE INFORMATION

Bitte vor dem Benutzen des Gerätes durchlesen und gut aufbewahren

IT

INFORMAZIONI IMPORTANTI

Leggere prima dell'uso e conservare per ulteriore consultazione

HU

Jótállást vállalni csak rendeltetésszerűen használatba vett gépekre tudunk. Kérjük, hogy a gép használatba vétele előtt gondosan olvassa el a kezelési utasításokat.

PL

Gwarancja traci ważność w przypadku używania urządzenia do celów innych niż wymienione w instrukcji obsługi. Prosimy o uważne przeczytanie instrukcji oraz o stosowanie się do zaleceń i wskazówek w niej zawartych

CZ

Záruka se nebude vztahovat na závady způsobené nesprávným používáním, nebo jestliže bude výrobek použit pro jiné účely než pro jaké byl vyroben, nebo také jinak než je uvedeno v návodu k obsluze. Tento návod si přečtěte, prosím, velmi pozorně a uchvejte jej pro možné budoucí odkazy

SK

Záruka na tento produkt nebude uznaná v prípade porúch spôsobených nesprávnou obsluhou alebo používaním výrobku na iný účel alebo iným spôsobom, ako je uvedené. Pred začatím práce si prosím dôkladne prečítajte návod na obsluhu a tento si aj pre prípad potreby uschovajte

SI

Garancija ne velja ob nepravilni uporabi proizvalca in/ali ob uporabi za drugi namen kot je izdelan. Prosimo, da pred uporabo, preverite pazljivo navodila za obratovanje in jih shranite za kasnejšo rabo.

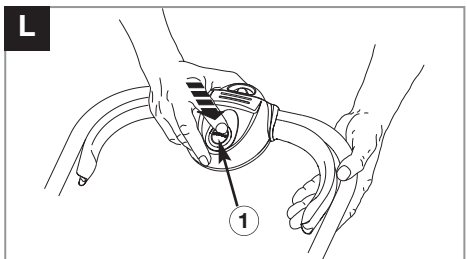
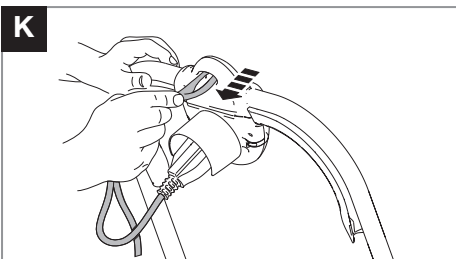
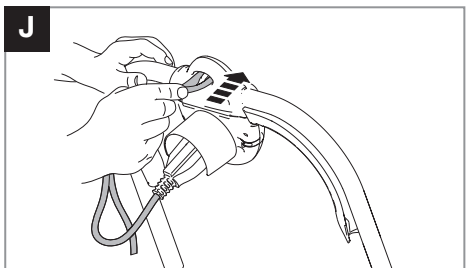
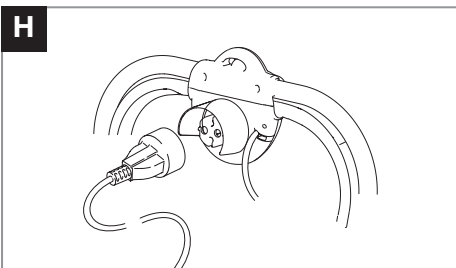
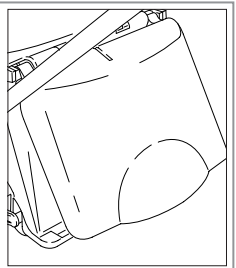
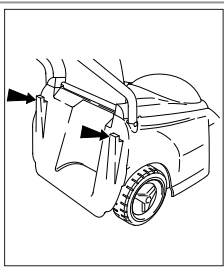
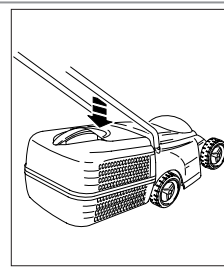
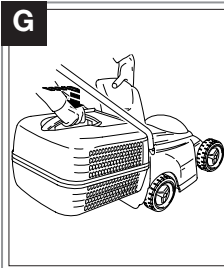
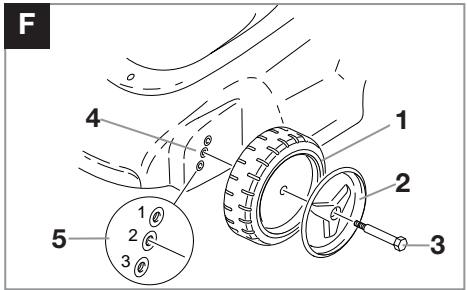
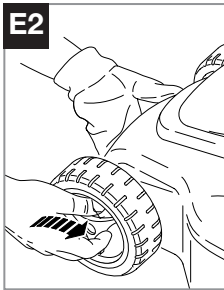
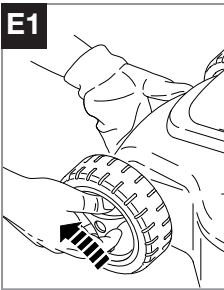
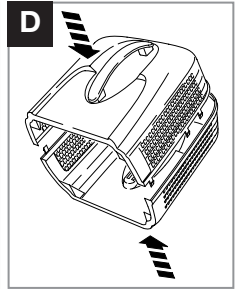
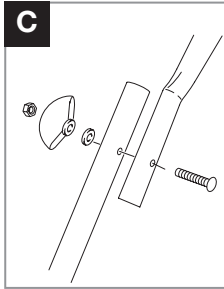
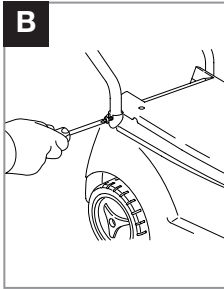
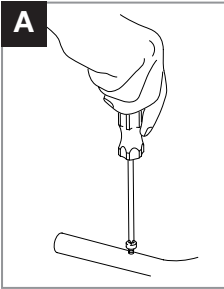

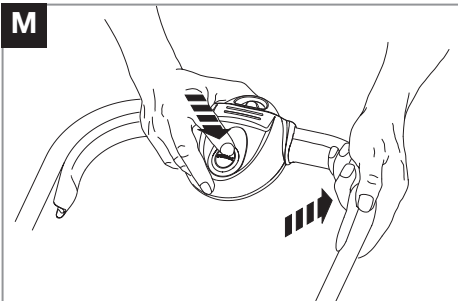
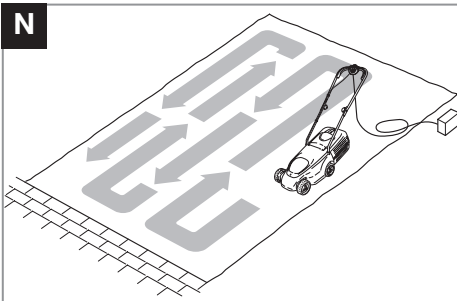
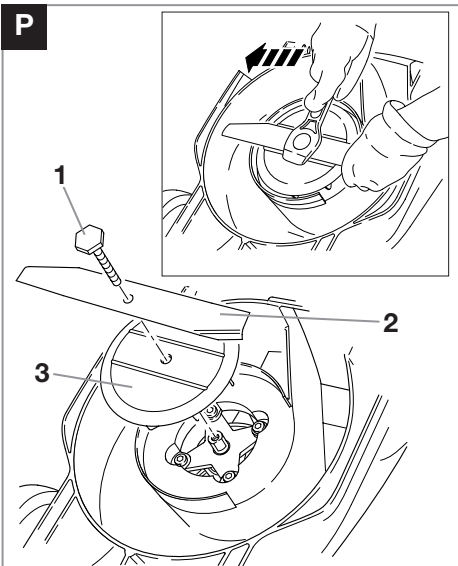
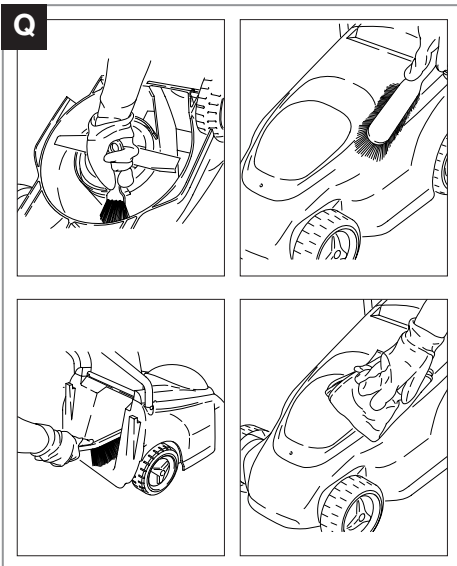
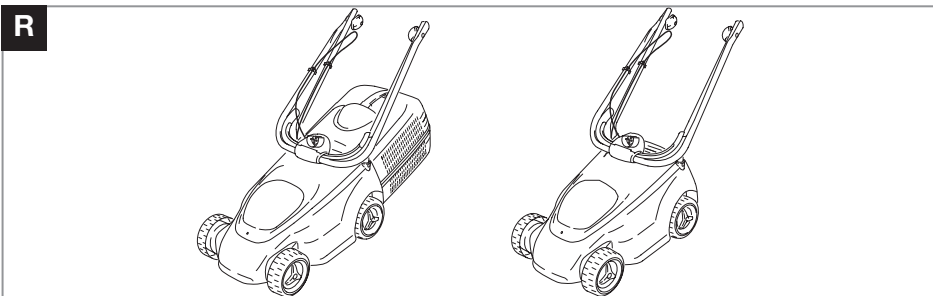
M**N****P****Q****R**

GB - CONTENTS

1. Switchbox
2. Lock off button
3. Start/stop lever
4. Upper handle
5. Cable clip
6. Bolt
7. Washer
8. Handle knob
9. Nut (if applicable)
10. Lower handle
11. Lower handle fixing screws
12. Motor Cover
13. Deck
14. Wheel assembly x 4
15. Safety Flap
16. Warning Label
17. Product Rating Label
18. Grassbox Upper
19. Grassbox Lower
20. Spanner/scraper tool
21. Instruction Manual

DE - INHALT

1. Schalter
2. Knopf zur Festsetzung in Aus-Position
3. Start-/Stoppebel
4. Oberer Griff
5. Kabelhalter
6. Bolzen
7. Unterlegscheibe
8. Griffknopf
9. Mutter (falls vorhanden)
10. Unterer Griff
11. Untere Befestigungsschrauben für Fahrbügel
12. Motorabdeckung
13. Chassis
14. Laufrad (4 Stck.)
15. Sicherungsklappe
16. Warnetikett
17. Produkttypenschild
18. Oberteil Fangbox
19. Unterteil Fangbox
20. Schraubenschlüssel/Reinigungswerkzeug
21. Bedienungsanweisung

IT - NOMENCLATURA

1. Casseta dell'interruttore
2. Pulsante di sblocco
3. Leva di avviamento
4. Impugnatura superiore
5. Morsetto per il cavo
6. Bullone
7. Rondella
8. Manopola dell'impugnatura
9. Dado (se pertinente)
10. Impugnatura inferiore
11. Viti di fissaggio del manico inferiore
12. Coperchio del motore
13. Telaio
14. Ruota x 4
15. Fascia protettiva
16. Etichetta di pericolo
17. Etichetta dati del prodotto
18. Parte superiore del cesto raccogliherba
19. Parte inferiore del cesto raccogliherba
20. Chiave/raschietto
21. Manuale di istruzioni

HU - TARTALOMJEGYZÉK

1. Kapcsolódoboz
2. Biztonsági gomb
3. Start/Stop kar
4. Felső tolókar
5. Kábelrögzítő
6. Csavar
7. Alátét
8. Rögzítógomb
9. Anya (ha van)
10. Alsó tolókar
11. Alsó kart rögzítő csavarok
12. Motor fedele
13. Borító
14. Kerék-összeállítás x 4
15. Biztonsági terelőlap
16. Figgelmeztető címke
17. Termékminősítő címke
18. Függyítő felső része
19. Függyítő alsó része
20. Csavarkulcs/térközbeállító szerszám
21. Kezelési útmutató

PL - ZAWARTOŚĆ KARTONU

1. Puszka przyłączeniowa
2. Przycisk ryglujący
3. Dźwignia start/stop
4. Górny uchwyt
5. Zaczep kabla
6. Śruba
7. Podkładka
8. Gałka mocująca
9. Nakrętka (jeżeli jest)
10. Dony uchwyt
11. Śruby mocujące dolnego uchwytu
12. Pokrywa silnika
13. Obudowa
14. Koła (4x)
15. Oslona zabezpieczająca
16. Znaki bezpieczeństwa
17. Tabliczka znamionowa
18. Górna część pojemnika na trawę
19. Dolna część pojemnika na trawę
20. Klucz/skrabak
21. Instrukcja obsługi

CZ - OBSAH

1. Spínací skřínka
2. Pojistné tlačítko
3. Spouštěcí/vypínací páka
4. Horní rukojeť
5. Úchytka kabelu
6. Šroub
7. Podložka
8. Otočný knoflík na rukojeti
9. Matice (pokud se používá)
10. Spodní rukojeť
11. Spojovací šrouby dolní rukojeti
12. Kryt motoru
13. Plášť
14. Sestava kol 4 kusy
15. Bezpečnostní vložka
16. Výstražný štítek
17. Typový štítek výrobku
18. Horní část koše na trávu
19. Dolní část koše na trávu
20. Klíč/nástroj pro čištění
21. Návod k obsluze

SK - OBSAH

1. Spínacia skrinka
2. Vypínacia zámka
3. Zapínač/vypínač
4. Vrchná rukoväť
5. Svorka na kábel
6. Skrutka
7. Podložka
8. Kĺb rukoväte
9. Matka (ak aplikovateľné)
10. Spodná rukoväť
11. Upevňovacie skrutky spodnej rukoväte
12. Kryt motora
13. Kryt
14. Kolesová súprava 4x
15. Bezpečnostná zámka
16. Varovný štítok
17. Prístrojový štítok
18. Vrchná časť schránky na trávu
19. Spodná časť schránky na trávu
20. Kľúč/skrabka
21. Príručka

SI - VSEBINA

1. Ohišje stikala
2. Varnostni stikalni gumb
3. Start-stop ročka
4. Zgornje držalo
5. Sponka za kabel
6. Vijak
7. Podložka
8. Pritrdilna matica
9. Matica (če je priložena)
10. Spodnje držalo
11. Pritrdilni vijaki za spodnje držalo
12. Pokrov motorja
13. Pokrov
14. Sestavna kolesa x 4
15. Varnostna loputa
16. Opozorilna Oznaka
17. Napisna Tablica
18. Zgornji deli zbiralnika trave
19. Spodnji del zbiralnika trave
20. Ključ/strgalo
21. Priročnik

(GB) CARTON CONTENTS
(DE) KARTONINHALT
(IT) CONTENUTO
(HU) A DOBOZ TARTALMA

(PL) ZAWARTOŚĆ KARTONU
(CZ) OBSAH KRABICE
(SK) OBSAH BALENIA
(SI) VSEBINA ŠKATLE

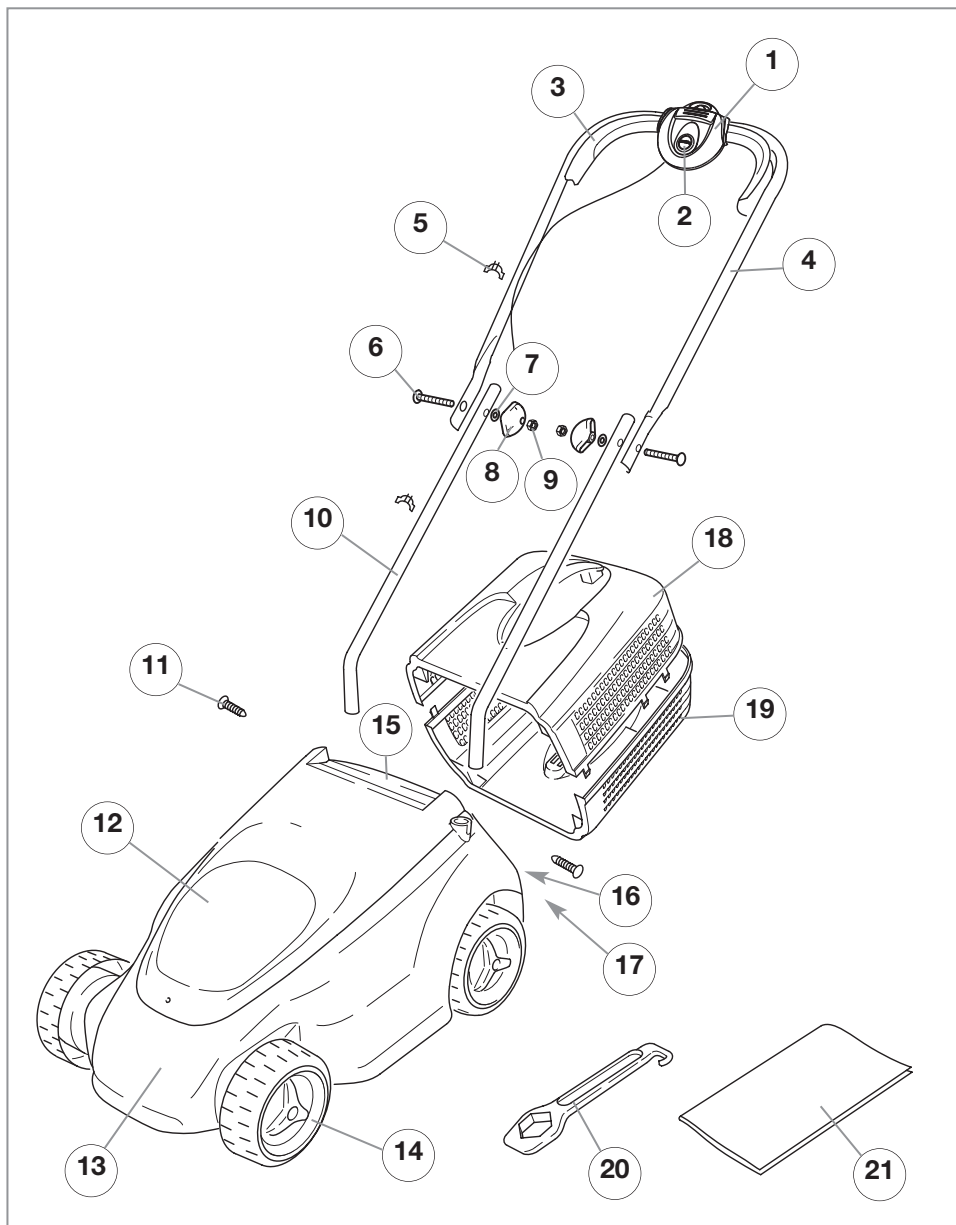

Safety Precautions



If not used properly this lawnmower can be dangerous! This lawnmower can cause serious injury to the operator and others, the warnings and safety instructions must be followed to ensure reasonable safety and efficiency in using this lawnmower. The operator is responsible for following the warning and safety instructions in this manual and on the lawnmower. Never use the mower unless the grassbox or guards provided by the manufacturer are in the correct position.

Explanation of Symbols on the RE320/RE32



Warning



Read the user instructions carefully to make sure you understand all the controls and what they do



Always keep the lawnmower on the ground when mowing. Tilting or lifting the lawnmower may cause stones to be thrown out

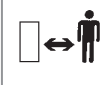

Keep bystanders away. Do not mow whilst people especially children or pets are in the mowing area



Switch off! Remove plug from mains before adjusting, cleaning or if cable is entangled or damaged. Keep the cable away from the blade.



Beware of severing toes or hands. Do not put hands or feet near a rotating blade.



Blade continues to rotate after the machine is switched off. Wait until all machine components have completely stopped before touching them.



Do not mow in the rain or leave the lawnmower outdoors while raining

General

1. Never allow children or people unfamiliar with these instructions to use the mower. Local regulations may restrict the age of the operator.
2. Only use the lawnmower in the manner and for the functions described in these instructions.
3. Never operate the lawnmower when you are tired, ill or under the influence of alcohol, drugs or medicine.
4. The operator or user is responsible for accidents or hazards occurring to other people or their property.

Electrical

1. The use of a Residual Current Device (R.C.D.) with a tripping current of not more than 30mA is recommended. Even with a R.C.D. installed 100% safety cannot be guaranteed and safe working practice must be followed at all times. Check your R.C.D. every time you use it.
2. Before use, examine cable for damage, replace it if there are signs of damage or ageing.
3. Do not use the lawnmower if the electric cables are damaged or worn

4. Immediately disconnect from the mains electricity supply if the cable is cut, or the insulation is damaged. Do not touch the electric cable until the electrical supply has been disconnected. Do not repair a cut or damaged cable. Replace it with a new one.
5. Your extension cable must be uncoiled, coiled cables can overheat and reduce the efficiency of your mower.
6. Keep cable away from lawnmower, always work away from the power point mowing up and down, never in circles.
7. Do not pull cable around sharp objects.
8. Always switch off at the mains before disconnecting any plug, cable connector or extension cable.
9. Switch off, remove plug from mains and examine electric supply cable for damage or ageing **before** winding cable for storage. Do not repair a damaged cable, replace it with a new one. Use only Flymo replacement cable.
10. Always wind cable carefully, avoiding kinking.
11. Never carry the product by the cable.
12. Never pull on the cable to disconnect any of the plugs.
13. Use only on AC mains supply voltage shown on the product rating label.
14. Flymo products are double insulated to EN60335. Under no circumstances should an earth be connected to any part of the product.

Cables

Use only 1.00mm² size cable up to 30 metres length maximum.

Maximum rating:

- 1.00mm² size cable 10 amps 250 volts AC
1. Mains cables and extensions are available from your local Electrolux Outdoor Products Approved Service Centre.
 2. Only use extension cables specifically designed for outdoor use.

Preparation

1. While using your product always wear substantial footwear and long trousers.
2. Make sure the lawn is clear of sticks, stones, bones, wire and debris; they could be thrown by the blade.
3. Before using the machine and after any impact, check for signs of wear or damage and repair as necessary.
4. Replace worn or damaged blades together with their fixings in sets to preserve balance.

Use

1. Use the lawnmower only in daylight or good artificial light.
2. Avoid operating your lawnmower in wet grass, where feasible.
3. Take care in wet grass, you may lose your footing.
4. On slopes, be extra careful of your footing and wear non-slip footwear.
5. Mow across the face of slopes, never up and down.

Safety Precautions

- Exercise extreme caution when changing direction on slopes. Walk never run.
- Mowing on banks and slopes can be dangerous. Do not mow on **banks** or **steep** slopes.
- Do not walk backwards when mowing, you could trip.
- Never cut grass by pulling the mower towards you.
- Switch off before pushing the mower over surfaces other than grass.
- Never operate the lawnmower with damaged guards or without guards in place.
- Keep hands and feet away from the cutting means at all times and especially when switching on the motor.
- Do not tilt lawnmower when the motor is running, except when starting and stopping. In this case, do not tilt more than absolutely necessary and lift only the part which is away from the operator. Always ensure that both hands are in the operating position before returning the appliance to the ground.
- Do not put hands near the grass discharge chute.
- Never pick up or carry a mower when it is operating or still connected to the mains supply.
- Remove the plug from the mains :
 - before leaving the mower unattended for any period;
 - before clearing a blockage;
 - before checking, cleaning or working on the appliance;
 - if you hit an object. Do not use your lawnmower until you are sure that the entire lawnmower is in a safe operating condition.;
 - if the lawnmower starts to vibrate abnormally. Check immediately. Excessive vibration can cause injury.

Maintenance and storage

- Keep all nuts, bolts and screws tight to be sure the lawnmower is in safe working condition.
- Check the grassbox/grassbag frequently for wear or deterioration.
- Replace worn or damaged parts for safety.
- Only use the replacement blade, blade bolt, spacer and impeller specified for this product.
- Be careful during adjustment of the lawnmower to prevent entrapment of the fingers between moving blades and fixed parts of the machine.

Assembly Instructions

Assembly of Lower Handles to Deck

- Locate 2 screws into the holes in the handles.
- Using a pozidrive screwdriver, secure the screws into the lower handles, ensuring the point of the screw stays inside the handle. **(A)**
- Insert lower handle with screw attached into hole in the deck and fully tighten screws. Repeat on the other side. **(B)**

NOTE: The screw will form its own thread.

Fitting Upper Handles to Lower Handles.(C)

- Ensure the upper handle is located correctly with the lock-off button on the switchbox uppermost.

- Ensure the upper handle and the lower handle are aligned correctly.
- Insert the nut into the handle knob. (if applicable)
- Fit the bolts, washers and handle knobs.
- Fit the cable to the handles with the clips provided, making sure the cables are not trapped between the upper and lower handles.

Grassbox Assembly. (D)

- Locate grassbox upper into grassbox lower. Align clips, ensure all clips are correctly located.
- Clip the two halves together.
- Ensure all clips are securely connected.

Adjusting the Cutting Height

F1 - Wheel

F2 - Hub cap

F3 - Fixing bolt

F4 - Mounting plate

F5 - Holes

- Height of cut is adjusted by raising or lowering the wheels.**
- NOTE: All 4 wheels must be adjusted to the same position:**

HEIGHT OF CUT

Low

Medium

High

WHEELS

Hole 1

Hole 2

Hole 3

- NOTE: A medium height of cut is recommended for most lawns.**

- To remove the wheel assembly turn the wheel hub in an anti-clockwise direction.**(E1)**
- Select one of the 3 holes in the mounting plate and note it as the other 3 wheels will need to be adjusted to the same position.**(F)**
- Locate fixing bolt through hole in hub cap, wheel and selected hole in mounting plate.**(F)**
- Turn the wheel hub in a clockwise direction until the wheel assembly is securely located to the deck.**(E2)**
- Using the same height adjustment position repeat the procedure for the other 3 wheels.

Grassbox

Fitting Fully Assembled Grassbox to Lawnmower. See Fig G.

- Lift safety flap.
- Make sure the discharge chute is clean and free from debris.
- Locate fully assembled grassbox onto 2 location points at the rear of the deck
- Locate safety flap onto the top of the grassbox. Ensure the grassbox is securely located.

- IMPORTANT! AFTER FITTING ENSURE NO GAP REMAINS BETWEEN THE SAFETY FLAP AND THE GRASSBOX.**

- Removal is the reverse procedure.
- For larger areas of grass where grass collection is not required you can use your lawnmower without the grassbox. Ensure the Safety Flap is fully closed. The design of the safety flap permits the cut grass to be discharged downward behind the machine.

Starting and Stopping

To Start your Lawnmower

1. Connect female extension cable connector to the back of the switchbox. **(H)**
2. Form loop in mains cable and push the loop through the slot. **(J)**
3. To secure, position loop over the hook and pull the cable back through the slot. **(K)**.
4. Connect plug to mains and switch on.
5. Tilt the handle downwards to slightly raise the front of the lawnmower and to reduce the risk of lawn damage whilst starting.

The switchbox is provided with a lock-off button (L1) to prevent accidental starting.

6. Press and hold the lock-off button **(L)** on the switchbox, then squeeze one of the Start/Stop levers towards the upper handle **(M)**.

7. Continue to squeeze the start/stop lever towards the upper handle and release the lock-off button.
8. Lower the lawnmower to its proper operating position and commence mowing.

NOTE:

There are two start/stop levers fitted. Either one can be used for starting the lawnmower.

IMPORTANT

Do not use the start/stop levers intermittently

To Stop your Lawnmower

1. Release the pressure on the Start/Stop lever.

How to Mow

1. Start mowing the edge of the lawn nearest to the power point so the cable is laid out on the lawn you have already cut. **(N)**
2. Cut your grass twice a week during the growing season, your lawn will suffer if more than a third of its length is cut at one time.

Do Not Overload Your Mower. Mowing long thick grass may cause the motor speed to drop, you will hear a change in the motor sound. If the motor speed drops you may overload your lawnmower which may cause damage. When mowing in long thick grass a first cut with the cutting height set higher will help reduce the load. See Adjusting the Cutting Height.

Removing and Fitting the Blade and Fan

P1 - Blade bolt

P2 - Blade

P3 - Fan

- **Always handle the blade with care - sharp edges could cause injury.**

- **USE GLOVES.**

Removing the Blade and Fan

1. To remove the blade bolt, hold the fan firmly and with the spanner provided loosen the blade bolt by turning it anti-clockwise **(P)**.
 2. Remove the blade bolt, blade and fan. **(P)**
 3. Inspect for damage and clean as necessary.
- **Renew your metal blade after 50 hours mowing or 2 years whichever is the sooner - regardless of condition.**

- **If the blade is cracked or damaged replace it with a new one.**
- **Never use a blade bolt if the insulated head is damaged cracked or missing.**

Fitting the Blade and Fan

1. Ensure the fan is located correctly. **(P)**
2. Fit the blade to the fan with the sharp edges of the blade pointing away from the fan.
3. Re-assemble blade bolt through blade and fan.
4. Hold the fan firmly and tighten blade bolt firmly with the spanner provided. Do not over tighten.
5. Do not use a longer spanner.

Caring for your Lawnmower

Cleaning (Q)

- **USE GLOVES**

- **IMPORTANT**

It is very important that you keep your lawnmower clean. Grass clippings left in any of the air intakes or under the deck could become a potential fire hazard.

1. Remove grass from under the deck with brush.
2. Using a soft brush - remove grass clippings from all air intakes, the discharge chute and the grass box.
3. Remove the blade, **see Figure P**, to gain access to the fan and clean with a soft brush.
4. Wipe over the surface of your lawnmower with a dry cloth.

- **IMPORTANT**

Never use water for cleaning your lawnmower. Do not clean with chemicals, including petrol, or solvents - some can destroy critical plastic parts.

At the End of the Mowing Season

1. Replace blade, bolts, nuts or screws, if necessary.
2. Clean your lawnmower thoroughly.
3. Make sure that the electric cable is coiled properly.

Storing your Lawnmower (R)

Store in a dry place where your lawnmower is protected from damage.

Environmental Information

Electrolux Outdoor Products are manufactured under an Environmental Management System (ISO 14001) using, where practical, components manufactured in the most environmentally responsible manner, according to company procedures, and with the potential for recycling at the end of the products' life.

- Packaging is recyclable and plastic components have been labelled (where practical) for categorised recycling.
- Awareness of the environment must be considered when disposing of 'end-of-life' product.
- If necessary, contact your local authority for disposal information.

Service Recommendations

- **Your product is uniquely identified by a silver and black product rating label.**
- **We strongly recommend that your product is serviced at least every twelve months, more often in a professional application.**

Fault Finding Hints

Fails to Operate

1. Is the Correct Starting procedure being followed?
See 'To Start your Lawnmower'
2. Is the Power Turned On?
3. Check the fuse in the plug, if blown replace.
4. Fuse continues to blow?

Immediately disconnect from the mains electricity supply and consult your local approved Service Centre.

Poor Grass Collection

1. Disconnect from the mains electricity supply.
2. Clean the outside of the air intakes, the discharge chute and the underside of the deck.
3. Raise to a higher height of cut. See Adjusting the Cutting Height
4. Clean Fan Blades.
5. **If poor collection persists.**

Immediately disconnect from the mains electricity supply and consult your local approved Service Centre.

Excessive Vibration

1. Disconnect from the mains electricity supply.
2. Check that the blade is fitted correctly?
3. If the blade is damaged or worn, replace it with a new one.
4. If vibration persists, turn the blade through 180° by first loosening the blade bolt, turning the blade and re-tightening the blade bolt.
5. If vibration persists?

Immediately disconnect from the mains electricity supply and consult your local approved Service Centre.

Lawnmower becomes heavy to push

1. Disconnect from the mains electricity supply.
2. In long grass or uneven ground, the height of cut should be raised to a higher position. See Adjusting the Cutting Height
3. Check that the wheels and rollers can rotate freely.
4. If problem persists?

Immediately disconnect from the mains electricity supply and consult your local approved Service Centre.

Guarantee and Guarantee Policy

If any part is found to be defective due to faulty manufacture within the guarantee period, Electrolux Outdoor Products, through its Authorised Service Repairers will effect the repair or replacement to the customer free of charge providing:

- (a) The fault is reported directly to the Authorised Repairer.
 - (b) Proof of purchase is provided.
 - (c) The fault is not caused by misuse, neglect or faulty adjustment by the user.
 - (d) The failure has not occurred through fair wear and tear.
 - (e) The machine has not been serviced or repaired, taken apart or tampered with by any person not authorised by Electrolux Outdoor Products.
 - (f) The machine has not been used for hire.
 - (g) The machine is owned by the original purchaser.
 - (h) The machine has not been used outside of the country for which it was specified.
 - (i) The machine has not been used commercially.
- * This guarantee is additional to, and in no way diminishes the customers statutory rights.

Failures due to the following are not covered, therefore it is important that you read the instructions contained in this Operator's Manual and understand how to operate and maintain your machine:

Failures not covered by guarantee

- * Replacing worn or damaged blades.
- * Failures as a result of not reporting an initial fault.
- * Failures as a result of sudden impact.
- * Failures as a result of not using the product in accordance with the instructions and recommendations contained in this Operator's Manual.
- * Machines used for hire are not covered by this guarantee.
- * The following items listed are considered as wearing parts and their life is dependent on regular maintenance and are, therefore not normally subject to a valid warranty claim:
Blades, Electric Mains cable.
- * **Caution!**
Electrolux Outdoor Products does not accept liability under the warranty for defects caused in whole or part, directly or indirectly by the fitting of replacement parts or additional parts that are not either manufactured or approved by Electrolux Outdoor Products, or by the machine having been modified in any way

BELGIQUE/BELGIË	Flymo Belgique/België Tel: 02 363 0311, Fax: 02 363 0391
ČESKÁ REPUBLIKA	Electrolux, spol. s.r.o., oz Electrolux Outdoor Products, Dobronická 635, 148 25 Praha 4 Tel: 02/6111 2408-9, Info-linka: 0800/110 220 Internet: www.partner-flymo.cz E-mail: info@husqvarna.cz
DANMARK	Electrolux Outdoor Products, Flymo/Partner A/S, Lundtoftegårdsvej 93A, DK 2800 Kgs.Lyngby Tel: 45 877577, www.flymo-partner.dk
DEUTSCHLAND	Flymo Deutschland Tel: 097 21 7640, Fax:097 21 764202
ESTONIA	Electrolux Estonia Ltd (Electrolux Eesti AS) Tel: (372) 6650010
FRANCE	Flymo France SNC Tel 01 46 67 8141, Fax 01 43 34 2491
FINLAND SUOMI	Flymo Finland Suomi Tel: 00 39611, Fax: 00 39 612632
ITALIA	McCulloch Italiana s.r.l. - Via Como 72, 23868 Valmadrera (LECCO) - ITALIA Tel: 800 017829, Fax: 0341 581671
IRELAND	Flymo Ireland Tel: 01 4565222, Fax: 01 4568551
MAGYARORSZÁG	Electrolux Lehel Kft Tel: 00 36 1 251 41 47
NORGE	Flymo/Partner, div. av Electrolux Motor a.s. Tel: 69 10 47 90
NEDERLAND	Flymo Nederland Tel: 0172-468322, Fax: 0172-468219
ÖSTERREICH	HUSQVARNA Zentralwerkstätte, Industriezeile 36, 4020 LINZ, Tel: 0732 770101-60, Fax: 0732 795922
POLSKA	Electrolux Poland Sp. z.o.o. Husqvarna, 01-612 Warszawa Myslowicka 10/2 Tel:- (22) 8332949
SLOVENIJA	SKANTEH d.o.o. Tel:- (061) 133 70 68, Fax:-(061) 133 70 68
SLOVENSKA	Electrolux Slovakia s.r.o., Borova Sihat 211, 033 01 Lipt. Hradok Tel: 044 522 14 19, Fax: 044 522 14 18, www.flymo-partner.sk
SCHWEIZ/SUISSE/SUIZZERA	Flymo Schweiz/Suisse/Suizzera Tel 062 889 93 50 / 889 94 25, Fax 062 889 93 60 / 889 94 35
SVERIGE	Electrolux Outdoor Products, Sverige Tel: 036 – 14 67 00, Fax: 036 – 14 60 70
UNITED KINGDOM	Electrolux Outdoor Products United Kingdom Tel: 01325 300303, Fax: 01325 310339

Electrolux Outdoor Products
Aycliffe Industrial Park
NEWTON AYCLIFFE
Co.Durham DL5 6UP
ENGLAND

Telephone - (00) 44 1325 300303 Fax - (00) 44 1325 310339

UK Telephone - 01325 300303 Fax - 01325 310339

Our policy of continuous improvement means that the specification of products may be altered from time to time without prior notice. Electrolux Outdoor Products manufacture products for a number of well known brands under various registered patents, designs and trademarks in several countries.

© Electrolux Outdoor Products Ltd. Registered Office, Electrolux Works, Oakley Road, Luton LU4 9QQ
Registered number 974979 England



The Electrolux Group. The world's No.1 choice.

The Electrolux Group is the world's largest producer of powered appliances for kitchen, cleaning and outdoor use. More than 55 million Electrolux Group products (such as refrigerators, cookers, washing machines, vacuum cleaners, chain saws and lawn mowers) are sold each year to a value of approx. USD 14 billion in more than 150 countries around the world.



5118994-03